

**B-SERIES CRAWLER EXCAVATORS
CX290B | CX350B | CX370B**

CASE
CONSTRUCTION



**BUILT
STRONG**

www.casece.com
EXPERTS FOR THE REAL WORLD
SINCE 1842

B-SERIES CRAWLER EXCAVATORS

DURABILITY BUILT IN

The upper-structure, redesigned to match increased hydraulic performance, ensures CASE legendary durability and reliability even in the toughest conditions. Boom and dipper feature forged brackets and reduced tolerances for increased component life minimizing downtime. Resin side shims on boom and dipper contribute to lower wear and service intervals. New synthetic hydraulic filter reduces system contamination, cutting service costs and boosting machine longevity.

LOW OPERATING COSTS

The certified fuel efficient powerful engine meets Tier III emissions regulations granting reduced fuel consumption. A large fuel tank, combined with low consumption, results in not more than a 2-day work period between refills. The Extended Maintenance System grants longer greasing intervals on all pins compared to competition. All filters and regular fill points are grouped for easy access. Radiator and cooler cores are mounted side by side for more efficient cooling and easy access for cleaning. Optional high flow refueling pump with automatic cut off reduces downtime for regular fills.

POWER AND SPEED

The advanced hydraulic system has three working modes offering higher breakout force, improved swing speeds and greater swing torque, resulting in faster cycle times and 5% increase in productivity. Power boost function is automatically engaged.

The electronic management of speed and power lowers fuel consumption and offers considerable productivity benefits in terms of outputs.



OPERATOR COMFORT

The widened cab structure offers more leg and foot space, while the extensive glass surface contributes to give an impression of aperture to the operator. Ergonomic layout, intuitive controls and a seat that lays flat ensures optimum comfort for all operators. Additionally, the viscous fluid cab mountings and top quality insulation lead to a stress and fatigue reduction for the operator, boosting productivity and performance. Four positions consoles with return to pre-set modes will suit operators of all sizes and needs

SAFETY FIRST

All round visibility in the cab is provided by a wide glazed area with single-piece window on the right hand side for unobstructed view. The frame structure has three times the structural rigidity of previous models, reducing noise and vibration for the operator. An adjustable control console with ergonomic design makes it easier to choose the correct operating mode, increasing comfort and safety.

HEAVY DUTY APPLICATIONS

On the CX370B a heavy duty boom with additional strength and reinforced components ensures strong performance and long operating life.



B-SERIES CRAWLER EXCAVATORS



ENGINE

The CX290B, CX350B and CX370B feature a proven six cylinder common rail engine meeting Tier 3 emissions standards. Compactness ensures extended durability for all components. The lower engine speed combined with the high capacity exhaust muffer provides 5% less noisy output and 20% more fuel saving. The fuel cooler contributes actively to grant fuel efficiency, while the overhead camshaft with four valves per cylinder and the exhaust gas recirculation system (EGR) reduce gaseous emissions. Auto and one-touch idle speed settings ensure maximum efficiency in all operating conditions.

All Case B series excavators can be equipped with hot climates cooling system (Tropical Package) to face temperatures above 45°.

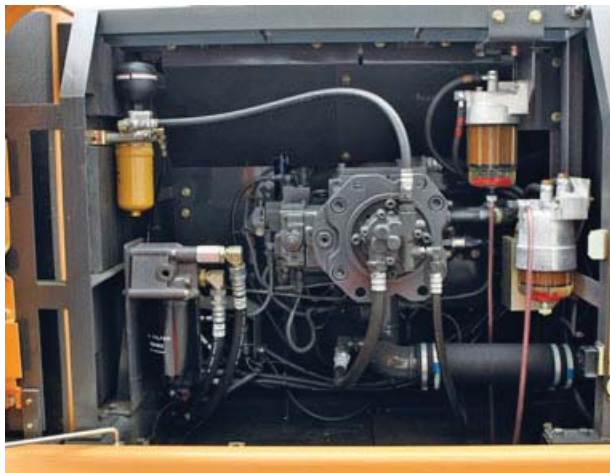

HYDRAULICS

All of Case B series Crawler excavators feature a variable control hydraulic pump which maintains optimum engine rpm during heavy load work. Controls provide rapid and smooth reactions to power demand, resulting in impressive productivity. The hydraulic system features improved piston pumps with tighter tolerances, reducing system losses and resulting, with the new swing relief system, in important fuel savings.

The hose burst control valves mounted behind the main lift cylinders have been designed for maximum safety.

A synthetic fibre hydraulic filter is provided as standard, protecting valuable components and prolonging hydraulic oil service life up to 5000 hours.



CONTROLS

Hydraulic system mode selection (three working modes available) is intuitively set through an advanced engine throttle control, easy reachable form the operator in the fully adjustable right hand console:

- A** A-MODE: for grading, lifting and precision work.
- H** H-MODE: the best balance between productivity and fuel economy.
- SP** SP-MODE: extra speed and power for the most demanding jobs that require maximum productivity.

Operators can store up to 10 auxiliary hydraulic flow settings in the machine's advanced hydraulic control, making it possible to use up to 10 attachments with no manual adjustment to the machine's hydraulic valves. This reduces downtime for attachment changeover, increasing productivity. The display console has a luminosity sensor to ensure that it is easy to read whatever the ambient light conditions.

**BUILT
STRONG**

OPERATOR'S CAB

The Case B series with its single-piece window and wide glazed surface provides best in class all around visibility. Despite re-profiled slim pillars, the cab is three times more rigid, for increased operator safety.

Combined with viscous cab mounts and reduced engine noise, this results in best-in-class insulation. All operators can find a comfortable position, thanks to adjustable consoles, fully reclining seat, unmatched leg room and air conditioning with nine outlet vents.

The B series cab features multiple standard options as the large storage box behind the driver's seat, bottle and can holders, a mobile phone holder and a cool box that uses the air conditioning system to regulate internal temperature.



B-SERIES CRAWLER EXCAVATORS



MAINTENANCE

Case CX B SERIES excavators are easy to service thanks to ground level access to all filters and maintenance points. The filters are remote mounted in a centralised position, providing easy and safe serviceability, and the larger fuel tank has both a drain valve and a removable service plate, when easy cleaning becomes essential as in case of fuel contamination.

An engine oil drainer cuts the risk of spillage during servicing, protecting the environment.

Centralised electrics positioned within the cab, behind the operator's seat ensure cleanliness and dry operating conditions.

In addition to this, the B series excavators scores the lowest time in SAE Maintenance comparative tests, outstanding for reduced downtime and cutting operating costs.



UNDERCARRIAGE

An outstanding undercarriage whose track components are designed for extended durability. Case sprockets are heat treated for longer service life. Durability of track guides and track links has been further improved, with new M shaped seals and increased pin hardness extending operating hours and boosting the Case reputation for robust durable design.

Furthermore, the track rollers have an O-ring design that prevents dirt and dust scaling.

IMPROVED PIN AND BUSHING LIFE

Extended Maintenance Bushings (EMS) are standard equipment on all Case CX B series excavators. These low maintenance bushings provide longer greasing intervals, greatly reducing daily and weekly maintenance for the operator, and increasing productivity. Anti-friction resin shims in the boom foot and head reduce noise and free play, increasing durability and reliability for the customer.



EMS chrome plated pins with brass bushing



Antifriction shims



ATTACHEMENTS AND BUCKETS

Case customers can choose from a variety of main booms and dipper arms to suit different applications, all of which are constructed of heavy duty steel box section with internal baffles to increase torsional rigidity. Deep groove welding ensures that the booms and arms can withstand the stress of high breakout forces, heavy lifting and attachments such as hydraulic breakers, compactors, demolition shears and crushers. On CX370B heavy duty boom and arm are offered as a standard. This versatility, along with a wide range of buckets from 0.47 m³ - 1.70 m³, provides a configuration for every customer's need and jobsite.

B-SERIES

CRAWLER EXCAVATORS

SPECIFICATIONS

CX290B

CX350B - CX370B

ENGINE			
Make	ISUZU		
Type	AH-6HK1XYSS		
Emission levels	Tier 3		
Common rail, turbo, intercooler, fuel cooler, EGR (Exhaust Gas Recirculator)	Yes		
Direct injection	Electronically controlled		
Number of cylinders	6		
Bore - Stroke (mm)	115 x 125		
Cubic capacity (cc)	7790		
Max power (kW/hp) EEC80/1269	154/206		202/275
(@rpm)	1800		2000
Maximum Torque (Nm)	850		1080
(@rpm)	1500		
HYDRAULIC SYSTEM			
Max output (l/min)	2 x 243		2 x 290
(@ rpm)	1800		1930
2 axial piston, variable flow pumps	Yes		
Attachment/Power Boost (bar)	343/373		
Upperstructure swing (bar)	294		304
Travel (bar)	343		
Oil filtration	6 micron		
Type of oil filter	Synthetic fiber super fine high catch		
SWING			
Max upperstructure swing speed (rpm)	10.2		9.8
Swing torque (kN-m)	92.5		112
TRAVEL			
	The travel circuit is equipped with axial piston, variable flow motors		
Max travel speed (km/h)	5.6		5.5
Low travel speed (km/h)	3.2		3.5
Speed change is controlled from the instrument panel			
Automatic downshifting	Yes		
Gradeability	70% (35)		
Tractive (daN)	23320		26520
ELECTRICAL SYSTEM			
Circuit (V)	24		
Batteries (V - A/h)	2 x 12 - 128		
Circuit equipped with water-proof connectors	Yes		
Alternator (V - Amp)	24 - 50		
UNDERCARRIAGE			
Upper rollers	2		2
Lower rollers	9		8
Number of track pads	50		48
Type of shoes	Triple grouser		
Track pad with standard (mm)	700		600
CIRCUIT AND COMPONENT CAPACITIES			
Fuel tank LC (l)	450		580
Hydraulic reservoir LC (l)	147		350
Hydraulic system (l)	300		175
Travel reduction gear (per side) (l)	9.1		9.5
Swing reduction gear (l)	6		7.9
Engine (including filter change) (l)	38		38
Engine cooling system (l)	29		30

CX290B GENERAL DIMENSIONS

With 6.15 m standard monoboam

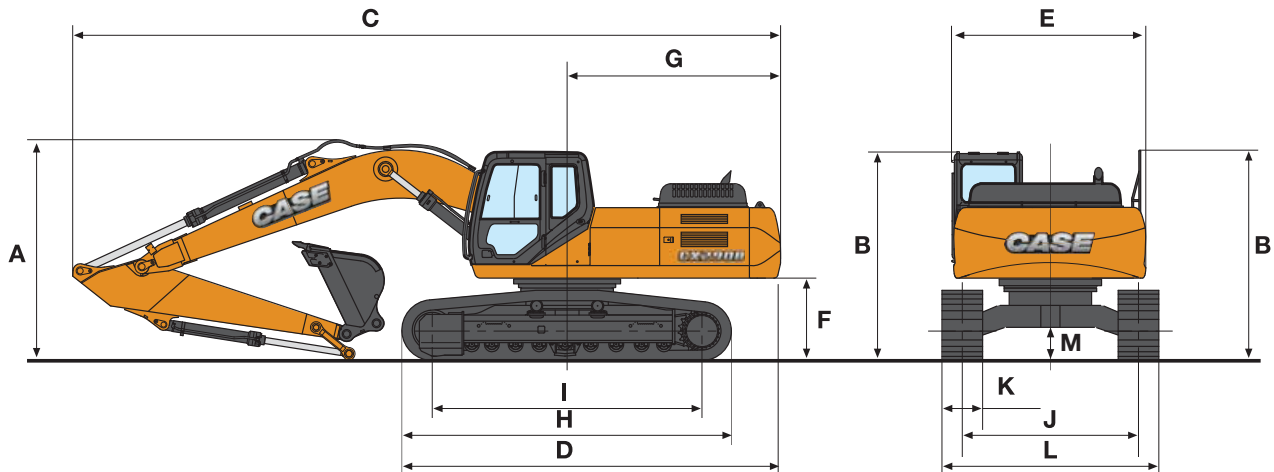

		CX290B LC MONO			
DIPPER LENGTH		2.65 m	3.18 m	3.60 m	
A	Overall height (with attachment)	m	3.34	3.26	3.46
B	Height (cab/handrail)	m	3.07/3.11	3.07/3.11	3.07/3.11
C	Overall length (with attachment)	m	10.48	10.45	10.47
D	Overall length (without attachment)	m	5.59	5.59	5.59
E	Width of upperstructure	m	2.87	2.87	2.87
F	Upperstructure ground clearance	m	1.19	1.19	1.19
G	Swing radius (rear end)	m	3.15	3.15	3.15
H	Track overall length	m	4.85	4.85	4.85
I	Centre idler to centre sprocket	m	3.98	3.98	3.98
J	Track gauge	m	2.60	2.60	2.60
K	Track shoe width standard	m	700	700	700
L	Track overall width - 600 mm shoes	m	3.20	3.20	3.20
	- 700 mm shoes	m	3.30	3.30	3.30
	- 800 mm shoes	m	3.40	3.40	3.40
M	Ground clearance	m	0.47	0.47	0.47

WEIGHT AND GROUND PRESSURE

With 6.15 m standard monoboam 3.18 m dipper 880 kg, 1.1 m³ bucket operator and full fuel tank

	LC	LC
Shoes 600 mm steel	29100	0.56
Shoes 700 mm steel	29500	0.49
Shoes 800 mm steel	29800	0.43

BUCKETS CX290B

GENERAL PURPOSE HEAVY DUTY											DITCH WITH BLADE DITCH WITH TEETH			HEAVY VERY DUTY	QUARRY
	475	640	810	940	1060	1180	1300	1430	1550	1700	1010	1250	1210	1300	1500
SAE capacity (l)	600	750	900	1000	1100	1200	1300	1400	1500	1600	2200	2200	2400	1300	1500
Width (mm)															

For other bucket sizes, please contact your CASE dealer

B-SERIES CRAWLER EXCAVATORS

CX290B PERFORMANCE DATA

With 6.15 m standard monoboam - 3.18 m dipper

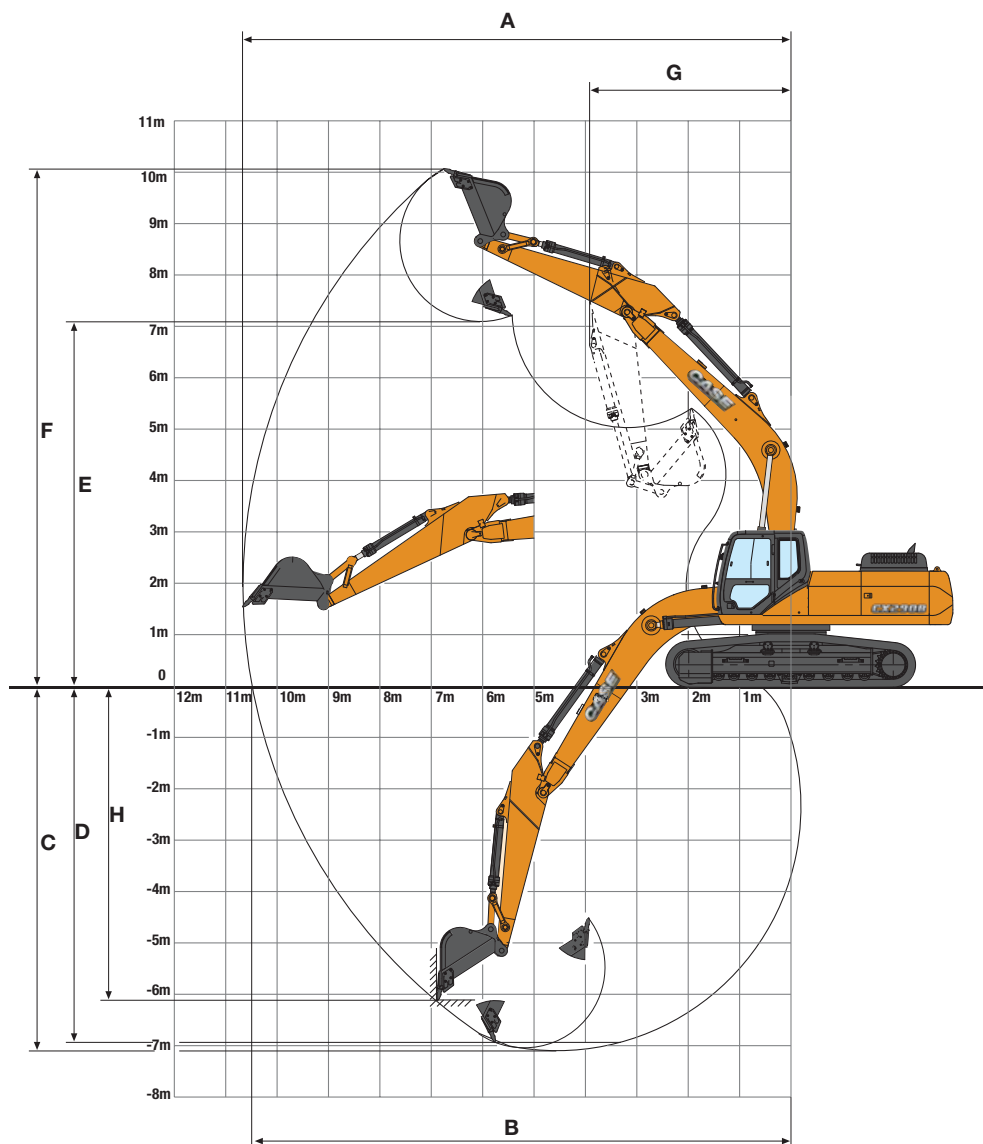

DIPPER LENGTH

		2.65 m	3.18 m	3.60 m	
A	Maximum digging reach	m	10.22	10.67	11.16
B	Maximum digging reach at ground level	m	10.04	10.50	10.99
C	Maximum digging depth	m	6.57	7.10	7.58
D	Digging depth - 2,44 m level bottom	m	6.39	6.94	7.44
E	Max dump height	m	6.94	7.09	7.39
F	Overall reach height	m	9.93	10.06	10.39
G	Minimum swing radius - attachment	m	4.00	3.92	4.00
H	Vertical straight wall dig depth	m	5.76	6.12	6.72
	Digging force - w/o Power Boost	daN	14 020	12 160	10 980
	- with Power Boost	daN	15 300	13 240	11 870
	Breakout force - w/o Power Boost	daN	17 460	17 460	17 460
	- with Power Boost	daN	19 020	19 020	19 020

LIFTING CAPACITY

CX290B

With 6.15 m standard monoboam

Values are expressed in kilos

Front Side	REACH											
	3.0 m		4.5 m		6.0 m		7.5 m		9.0 m		At max reach	

LC UNDERCARRIAGE - 3.66 m dipper, 700 mm shoes, bucket of 1.0 m³ (790 kg)

7.5 m							4206*	4206*			3510*	3510*	7.82
6.0 m							5509*	5509*			3428*	3428*	8.71
4.5 m							6697*	5345	4318*	3861	3488*	3488*	9.27
3.0 m	17854*	17854*	11434*	11434*	8891*	7284	7563*	5085	5527*	3728	3678*	3344	9.56
1.5 m	8616*	8616*	14177*	10523	10310*	6797	7678	4818	5728	3583	4021*	3208	9.6
0 m	8681*	8681*	15811*	9893	10592	6425	7435	4598	5598	3463	4584*	3226	9.41
-1.5 m	11392*	11392*	16184*	6917	10346	6211	7284	4461			5535*	3422	8.96
-3.0 m	15346*	15346*	15456*	9580	10276	6149	7249	4430			6335	3891	8.22
-4.5 m	19035*	19035*	13530*	9733	10065*	6242					8039	4926	7.07
-6.0 m	13252*	13252*	9675*	9675*							8053*	7908	5.28

LC UNDERCARRIAGE - 3.18 m dipper, 700 mm shoes, bucket of 1.1 m³ (806 kg)

7.5 m											4258*	4258*	7.17
6.0 m							5807*	5491			4191*	4191*	8.13
4.5 m					8151*	7682	7314*	5313			4311*	4076	8.73
3.0 m	16268*	16268*	12497*	11298	9512*	7217	7951	5074	4786*	3741	4607*	3715	9.04
1.5 m	6623*	6623*	14994*	10406	10819*	6774	7685	4833	5632*	3620	5121*	3564	9.09
0 m	8682*	8682*	16224*	9904	10611	6455	7476	4645			5772	3598	8.88
-1.5 m	12411*	12411*	16202*	9724	10424	6291	7362	4542			6212	3853	8.4
-3.0 m	17248*	17248*	15101*	9751	10406	6276	7374	4552			7230	4496	7.6
-4.5 m	17383*	17383*	12708*	9962	9430*	6425					8739*	5928	6.35

LC UNDERCARRIAGE - 2.65 m dipper, 700 mm shoes, bucket of 1.3 m³ (868 kg)

7.5 m											5526*	5526*	6.59
6.0 m							7785*	7785*	5958*	5373	5451*	5216	7.62
4.5 m					10696*	10696*	8753*	7528	7741*	5216	5638*	4413	8.26
3.0 m					13456*	10968	10029*	7070	7863	4991	6072*	3997	8.58
1.5 m					15594*	10158	10846	6656	7618	4771	6108	3831	8.64
0 m			7798*	7798*	16323*	9778	10531	6382	7440	4610	6244	3886	8.42
-1.5 m			13241*	13241*	15865*	9691	10401	6268	7367	4544	6804	4212	7.92
-3.0 m			19540*	19540*	14360*	9790	10446	6307			8135	5010	7.06
-4.5 m			15044*	15044*	11402*	10085					8936*	7079	5.68

* The above loads (kg) are compliant to the ISO standards and refer to the excavator equipped with bucket. The indicated loads are no more than 87% of hydraulic system lift capacity or 75% of static tipping load. Values marked with an asterisk (*) are limited by the hydraulic lifting capacity rather than the tipping load.

B-SERIES CRAWLER EXCAVATORS

CX350B / CX370B GENERAL DIMENSIONS

With 6.45 m standard monoboam

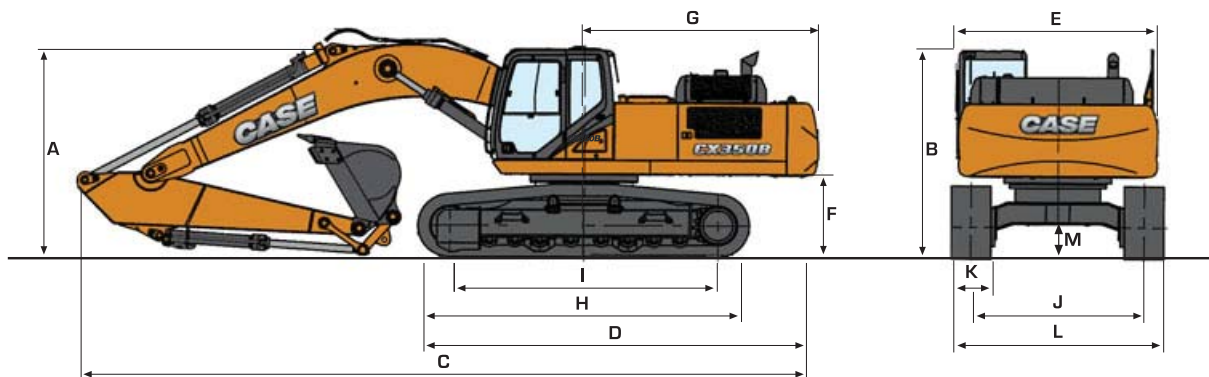

DIPPER LENGTH

		2.21 m	2.63 m	3.25 m	4.04 m*	
A	Overall height (with attachment)	m	3.51	3.50	3.26	3.48
B	Height (cab/handrail)	m	3.13	3.13	3.13	3.13
C	Overall length (with attachment)	m	11.26	11.13	11.05	11.09
D	Overall length (without attachment)	m	5.91	5.91	5.91	5.91
E	Width of upperstructure	m	3.02	3.02	3.02	3.02
F	Upperstructure ground clearance	m	1.21	1.21	1.21	1.21
G	Swing radius (rear end)	m	3.45	3.45	3.45	3.45
H	Track overall length	m	4.98	4.98	4.98	4.98
I	Centre idler to centre sprocket	m	4.04	4.04	4.04	4.04
J	Track gauge	m	2.60	2.60	2.60	2.6
K	Track shoe width standard	mm	600	600	600	600
L	Track overall width - 600 mm shoes	m	3.20	3.20	3.20	3.2
	- 700 mm shoes	m	3.40	3.40	3.40	3.4
	- 800 mm shoes	m	3.60	3.60	3.60	3.6
	- 900 mm shoes	m	3.80	3.80	3.80	3.8
M	Ground clearance	m	0.48	0.48	0.48	0.48

* Only available on CX350B

WEIGHT AND GROUND PRESSURE

With 3,25 arm - 1,4 m³ bucket, lubricant, coolant, operator and full fuel tank

CX350B	WEIGHT (kg)	GROUND PRESSURE (MPa)
shoes 600 mm steel	34200	0.064

Counterweight: 6400 Kg

BUCKETS CX350B / CX370B

GENERAL PURPOSE

	740	940	1150	1360	1580	1800	2010
SAE capacity (l)	740	940	1150	1360	1580	1800	2010
Width (mm)	750	900	1050	1200	1350	1500	1650
Weight (kg)	770	820	910	1000	1150	1230	1330

QUARRY

SAE capacity (l)	2010
Width (mm)	1650
Weight (kg)	1660

With 3,25 arm - 1,4m³ HD bucket, lubricant, coolant, operator and full fuel tank

CX370B	WEIGHT (kg)	GROUND PRESSURE (MPa)
shoes 600 mm steel	36200	0.068

Counterweight: 7400 Kg

HEAVY DUTY

	740	940	1150	1360	1580	1800	2010
SAE capacity (l)	740	940	1150	1360	1580	1800	2010
Width (mm)	750	900	1050	1200	1350	1500	1650
Weight (kg)	864	938	1096	1243	1350	1429	1537

EXTRA HEAVY DUTY

SAE capacity (l)	1360
Width (mm)	1200

For other bucket sizes, please contact your CASE dealer

CX350B / CX370B PERFORMANCE DATA

with 6.45 m standard monoboomb

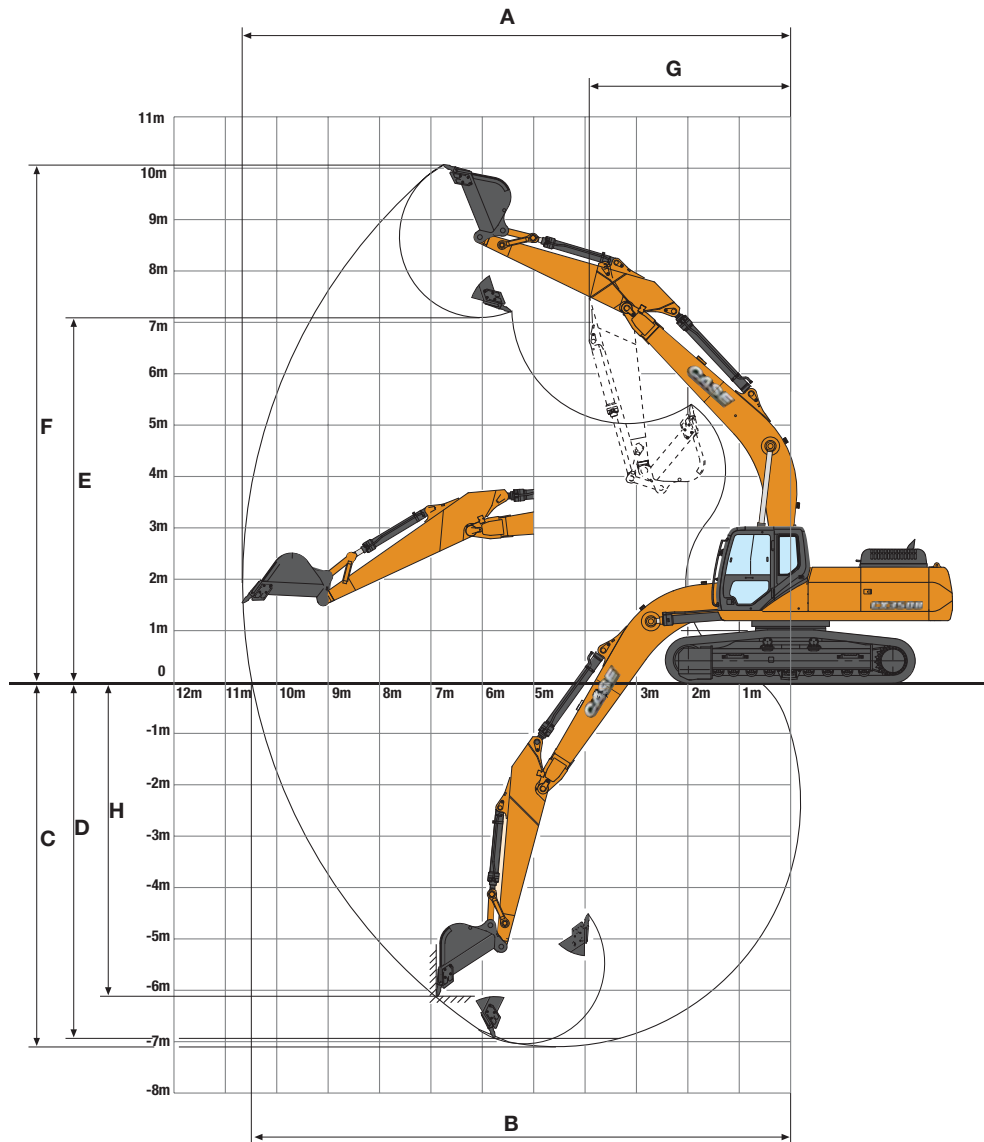

DIPPER LENGTH

			2.21 m	2.63 m	3.25 m	4.04 m
A	Maximum digging reach	m	10.2	10.67	11.17	11.9
B	Maximum digging reach at ground level	m	9.99	10.47	10.98	11.72
C	Maximum digging depth	m	6.30	3.73	7.34	8.14
D	Digging depth - 2.44 m level bottom	m	6.10	6.55	7.19	8.01
E	Max dump height	m	6.77	7.14	7.23	7.54
F	Overall reach height	m	9.85	10.32	10.37	10.67
G	Minimum swing radius - attachment	m	4.66	4.63	4.50	4.56
H	Vertical straight wall dig depth	m	5.08	5.97	6.35	7.15
	Digging force - w/o Power Boost	daN	22700	19500	16400	14100
	- with Power Boost	daN	24600	21100	17800	15300
	Breakout force - w/o Power Boost	daN	22880	22880	22880	22880
	- with Power Boost	daN	24840	24840	24840	24840

LIFTING CAPACITY

CX350B

With 6.45 m standard monoboam



LC UNDERCARRIAGE - 2.21 m arm length, 600 mm shoes, bucket of 1.6 m³ (1239 kg). Maximum reach 8.63 m

7.5 m											8777*	8508	6.33
6.0 m				9383*	9055	8607*	6094				8564*	5847	7.67
4.5 m			13555*	13432	10543*	8481	9056*	5853			7984	4907	8.27
3.0 m			16600*	11924	11933*	7824	9115	5533			7305	4417	8.58
1.5 m			18352*	11017	12494	7291	8791	5242			7079	4223	8.61
0 m			18438*	10745	12145	6989	8580	5052			7264	4296	8.38
-1.5 m	18703*	18703*	17487*	10773	12053	6909	8530	5007			7981	4701	7.85
-3.0 m	19964*	19964*	15532*	11007	11920*	7037					9694	5700	6.96
-4.5 m			11950*	11510							9752*	8367	5.54

LC UNDERCARRIAGE - 2.63 m arm length, 600 mm shoes, bucket of 1.6 m³ (1239 kg). Maximum reach 9.18 m

7.5 m											8021*	7424	6.86
6.0 m						8066*	6153				6596*	5070	8.28
4.5 m					9943*	8584	8603*	5883			6735*	4327	8.85
3.0 m			15681*	12250	11419*	7911	9133	5543	6724	4033	6553	3927	9.13
1.5 m			17885*	11186	12554	7334	8780	5225	6555	3882	6364	3764	9.17
0 m			18485*	10749	12136	6972	8530	5000			6504	3816	8.95
-1.5 m	15930*	15930*	17892*	10681	11976	6833	8427	4907			7053	4129	8.45
-3.0 m	21906*	21906*	16262*	10843	12048	6895	8518	4989			8301	4871	7.64
-4.5 m	17240*	17240*	13200*	11246	9849*	7202					9009*	6624	6.37

LC UNDERCARRIAGE - 3.25 m arm length, 600 mm shoes, bucket of 1.4 m³ (1169 kg). Maximum reach 9.67 m

7.5 m							6372*	6372*			6026*	6026*	7.62
6.0 m							7407*	6325			4537*	4537*	8.83
4.5 m					9138*	8845	8039*	6036	6562*	4304	4636*	3977	9.36
3.0 m	13761*	13761*	14412*	12841	10734*	8164	8881*	5677	6813	4122	4902*	3624	9.63
1.5 m	7198*	7198*	17144*	11619	12219*	7539	8893	5329	6608	3933	5371*	3470	9.66
0 m	10610*	10610*	18426*	10971	12282	7102	8595	5061	6448	3786	5973	3496	9.45
-1.5 m	15484*	15484*	18387*	10751	12028	6881	8428	4911			6397	3734	8.99
-3.0 m	21488*	21488*	17249*	10798	11999	6857	8422	4905			7345	4298	8.22
-4.5 m	20317*	20317*	14834*	11073	11138*	7033					8928*	5547	7.6
-6.0 m			10201*	10201*							8572*	8572*	5.24

LC UNDERCARRIAGE - 4.04 m arm length, 600 mm shoes, bucket of 1.15 m³ (1046 kg). Maximum reach 10.43 m

7.5 m											4513*	4513*	8.57
6.0 m									5444*	4545	3460*	3460*	9.65
4.5 m							7152*	6176	6683*	4378	3510*	3406	10.1
3.0 m			12401*	12401*	9573*	8401	8076*	5773	6855	4152	3677*	3112	10.4
1.5 m	12183*	12183*	15558*	11976	11256*	7672	8943	5364	6599	3917	3977*	2971	10.4
0 m	11487*	11487*	17603*	11021	12303	7107	8506	5024	6381	3717	4462*	2971	10.2
-1.5 m	14351*	14351*	18274*	10576	11912	6668	8315	4800	6241	3588	5240*	3129	9.79
-3.0 m	18657*	18657*	17793*	10475	11766	6642	8217	4712	6222	3570	6122	3513	9.01
-4.5 m	23128*	22228	16143*	10630	11847	6712	8302	4788			7448	4313	8.07
-6.0 m	17821*	17820*	12857*	11055	9412*	7025					8256*	6193	6.54

* The above loads (kg) are compliant to the ISO standards and refer to the excavator equipped with bucket. The indicated loads are no more than 87% of hydraulic system lift capacity or 75% of static tipping load. Values marked with an asterisk (*) are limited by the hydraulic lifting capacity rather than the tipping load.

LIFTING CAPACITY

CX370B

With 6.45 m standard monoboam

Front Side	REACH											
	3.0 m	4.5 m	6.0 m	7.5 m	9.0 m	At max reach	m					

LC UNDERCARRIAGE - 2.21 m arm length, 600 mm shoes, bucket of 1.6 m³ (1573 kg). Maximum reach 8.63 m

7.5 m											8431*	8431*	6.33
6.0 m				9032*	9032*	8239*	6400				8194*	6134	7.67
4.5 m				13161*	13161*	10164*	8977	8677*	6147		8229*	5128	8.27
3.0 m				16127*	12705	11518*	8281	9323*	5809		7638	4604	8.58
1.5 m				17826*	11734	12601*	7714	9232	5500		7397	4398	8.61
0 m				17894*	11440	12819	7390	9007	5298		7596	4479	8.38
-1.5 m	18437*	18437*	16944*	11469	12720	7340	8951	5248			8363	4917	7.85
-3.0 m	19317*	19317*	15000*	11717	11453*	7437					9503*	5993	6.96
-4.5 m				11443*	11443*						9289*	8862	5.54

LC UNDERCARRIAGE - 2.63 m arm length, 600 mm shoes, bucket of 1.6 m³ (1573 kg). Maximum reach 9.18 m

7.5 m											7595*	7595*	6.86
6.0 m							7621*	6399			6285*	5233	8.28
4.5 m					9475*	9010	8138*	6109			6422*	4435	8.85
3.0 m					15093*	12933	10901*	8282	8852*	5741	6946	4123	9.13
1.5 m					17222*	11777	12128*	7656	9135	5397	6764	3956	9.17
0 m					17792*	11302	12699	7264	8864	5153			8.95
-1.5 m	15621*	15621*	17194*	11229	12525	7113	8752	5052			7291	4219	8.45
-3.0 m	21060*	21060*	15576*	11405	11729*	7181	8806*	5141			8542*	5014	7.64
-4.5 m	16437*	16437*	12542*	11844	9267*	7514					8454*	6894	6.37

LC UNDERCARRIAGE - 3.25 m arm length, 600 mm shoes, bucket of 1.4 m³ (1498 kg). Maximum reach 9.67 m

7.5 m							6047*	6047*			5700*	5700*	7.62
6.0 m							6950*	6568			4212*	4212*	8.83
4.5 m					8664*	8664*	7558*	6254	6238*	4388	4311*	4035	9.36
3.0 m	13429*	13429*	13825*	13542	10202*	8532	8369	5862	7021	4191	4579*	3655	9.63
1.5 m	6871*	6871*	16456*	12197	11631*	7845	9165*	5482	6798	3985	5048*	3488	9.66
0 m	10283*	10283*	17684*	11483	12564*	7365	8905	5188	6623	3825	5814*	3515	9.45
-1.5 m	15157*	15157*	17629*	11243	12541	7124	8724	5025			6568	3769	8.99
-3.0 m	21159*	21159*	16498*	11299	12230*	7099	8717	5019			7576	4372	8.22
-4.5 m	19415*	19415*	14109*	11606*	10510*	7295					8350*	5711	7.06
-6.0 m				9528*	9528*						7949*	7949*	5.24

* The above loads (kg) are compliant to the ISO standards and refer to the excavator equipped with bucket. The indicated loads are no more than 87% of hydraulic system lift capacity or 75% of static tipping load. Values marked with an asterisk (*) are limited by the hydraulic lifting capacity rather than the tipping load.

www.casece.com

EXPERTS FOR THE REAL WORLD
SINCE 1842

CASE

CONSTRUCTION



Form No. AME5305CCGB - Printed in Italy - MediaCross Firenze - 09/15

**CASE CONSTRUCTION EQUIPMENT
CONTACT INFORMATION**

CNH INDUSTRIAL - TORINO
Via Plava 80
10135 Torino
Italy

CNH INTERNATIONAL S.A. - LUGANO
Riva Paradiso 14
6902 Paradiso - Lugano
Switzerland

CNH INDUSTRIAL - MIDDLE EAST
Dubai Regional Representative Office
Dubai Airport Free Zone, Building 2W
Office 201 - PO Box 54588
Dubai, United Arab Emirates

CNH INDUSTRIAL - SOUTH AFRICA
N1 Business Park
Slate Avenue
Cosmosdal
South Africa

NOTE: Standard and optional fittings can vary according to the demands and specific regulations of each country. The illustrations may include optional rather than standard fittings - consult your Case dealer. Furthermore, CNH Industrial reserves the right to modify machine specifications without incurring any obligation relating to such changes.

Conforms to directive 2006/42/EC

